

PRESSURE CONTROL VALVES



PRESSURE CONTROL VALVES

INTRODUCTION

PROPORTIONAL IT PRESSURE REDUCING VALVES

The proportional IT pressure reducing valves, are made to remotely control directional control valves with hydraulic actuators or to control variable displacement pump regulator devices.

Thanks to the special architecture that enables all the components to be build into the electro-proportional coil, the IT pressure reducing valves are very compact having a flange mounting assembly, this solution does not require any machining of the cavity.

Feeding the coil with current (PWM 120Hz) from “0” to “I max” it is possible to create a proportional increase of the regulated pressure in the V port.

Besides the IT27 version, as a single components, we can offer solutions that are already assembled into a body with CETOP 2 and CETOP 3 flanging or for in-line assembly.

IN LINE SEQUENCE VALVES

The sequence valves are used when it is necessary to hydraulically control the sequence of two or more movement using a single source of power, establishing the priority of a movement versus another one. As an example, we may allow the start of a cylinder only after the system reaches a specific pressure. Sequence valve are based on a relief valve combined with a check valve that allow the oil passage in reverse with a low pressure drop.

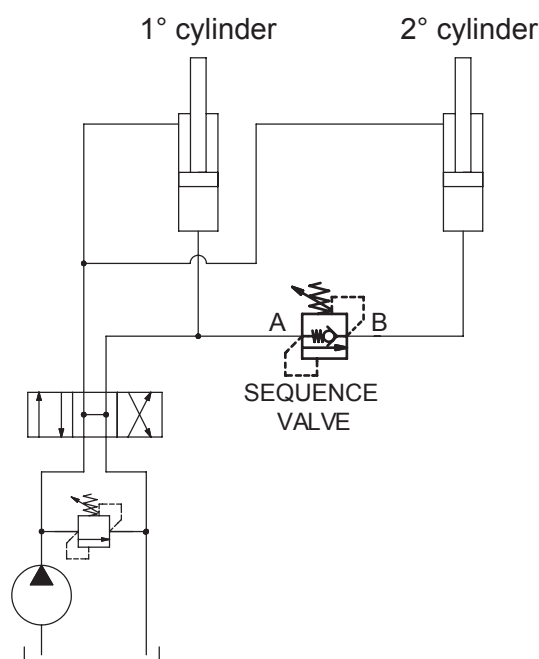

As per the relief valves, also the sequence valves can be produced as direct acting or pilot operated as well as fully balanced not sensitive to back pressure.

PROPORTIONAL PRESSURE REDUCING VALVE FLANGE MOUNTING

- Max working pressure in P..... **50 bar**
- Max working pressure in L..... **1 bar**
- Max working flow..... **2 l/min**
- Leakage..... **8 cc/min**
- Seals..... **NBR**
- Max current at 12 Vcc..... **1800 mA**
- Max current at 24 Vcc..... **900 mA**
- Hysteresis..... **5%**
- PWM..... **120 HZ**
- Protection index with standard connector..... **IP-65**
- Screw tightening torque..... **3 Nm**
- Weight..... **0,44 Kg**

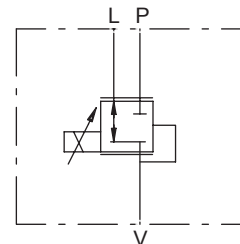

COIL RESISTANCE [Ω]		VOLTAGE	
		1 (12Vcc)	2 (24Vcc)
REDUCED PRESSURE	1 (3+18 bar)	3,7	15,5
	2 (3+28 bar)	3,7	15,5
	3 (3+33 bar)	4,8	19,3

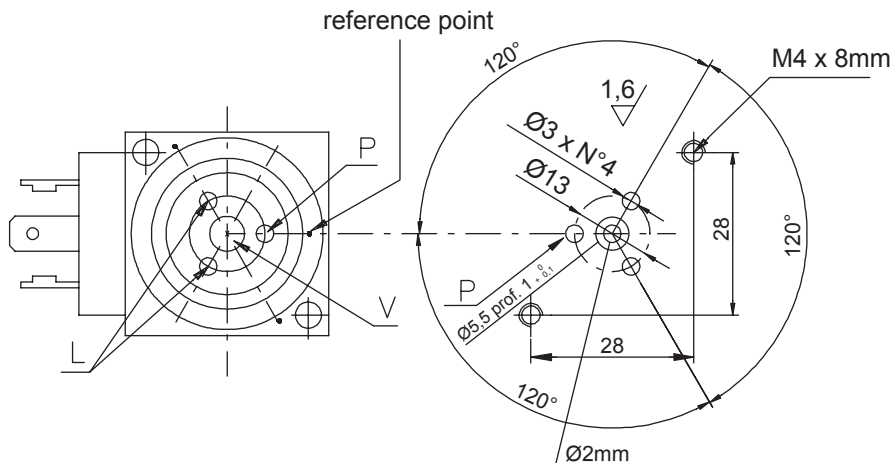
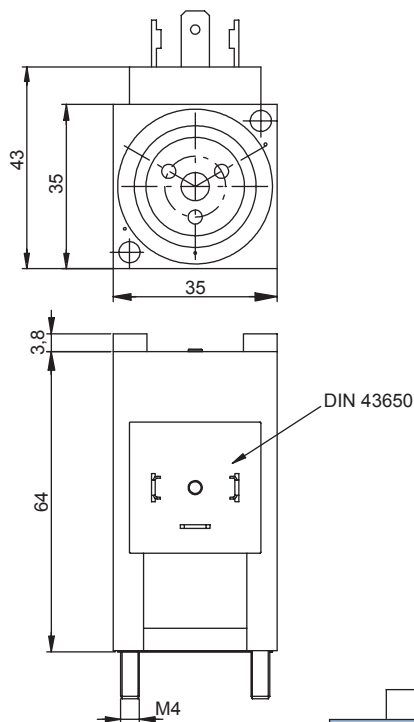
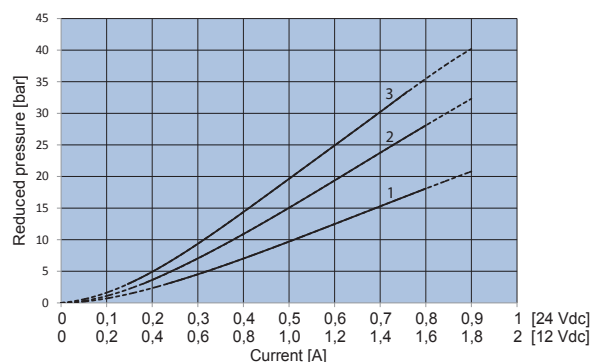

Ordering code

1 0 2 7 0 0 **0 0**

VOLTAGE	
1	2
12 Vcc	24Vcc

REDUCED PRESSURE		
1	2	3
3+18 bar	3+28 bar	3+33 bar



DOUBLE PROPORTIONAL PRESSURE REDUCING VALVE

- Max working pressure in P **50 bar**
- Max working pressure in T **1 bar**
- Max working flow **2 l/min**
- Leakage **8 cc/min**
- Seals **NBR**
- Max current at 12 Vcc **1800 mA**
- Max current at 24 Vcc **900 mA**
- Hysteresis **5%**
- PWM **120 HZ**
- Protection index with standard connector **IP-65**
- Weight **1,42 Kg**

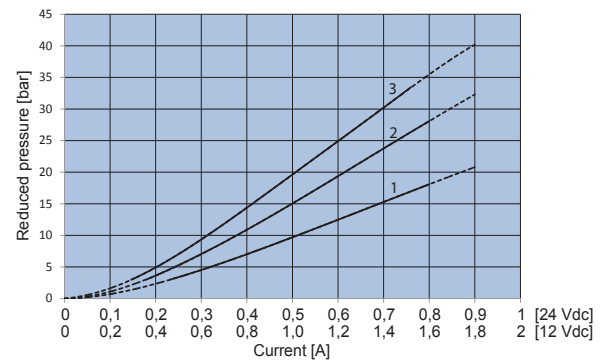
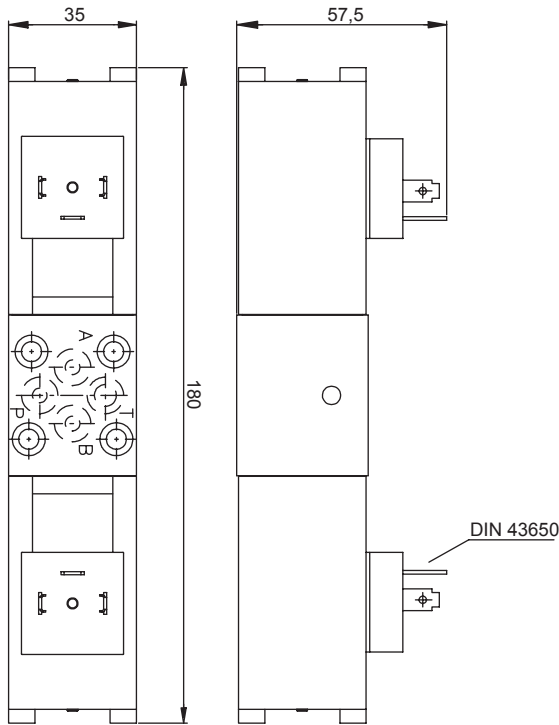
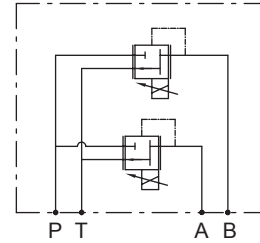

		VOLTAGE	
		1 (12Vcc)	2 (24Vcc)
REDUCED PRESSURE	1 (3÷18 bar)	3,7	15,5
	2 (3÷28 bar)	3,7	15,5
	3 (3÷33 bar)	4,8	19,3

Ordering code

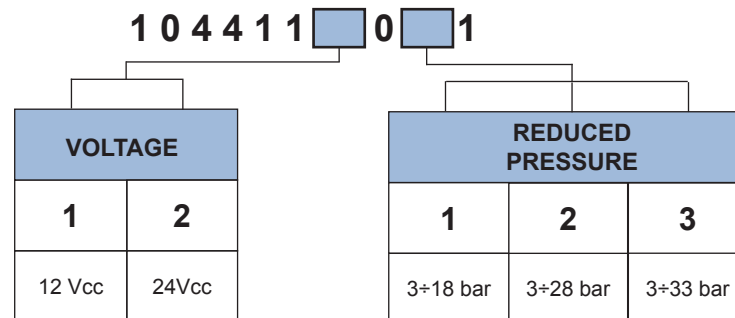

DOUBLE PROPORTIONAL PRESSURE REDUCING VALVE

- Max working pressure in P **50 bar**
- Max working pressure in T **1 bar**
- Max working flow. **2 l/min**
- Leakage..... **8 cc/min**
- Seals..... **NBR**
- Max current at 12 Vcc **1800 mA**
- Max current at 24 Vcc **900 mA**
- Hysteresis..... **5%**
- PWM **120 HZ**
- Protection index with standard connector..... **IP-65**
- Weight **1,42 Kg**

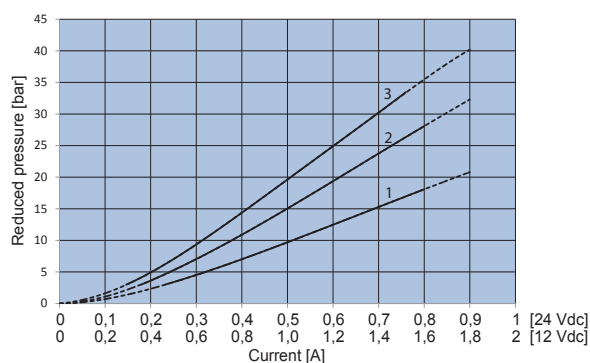
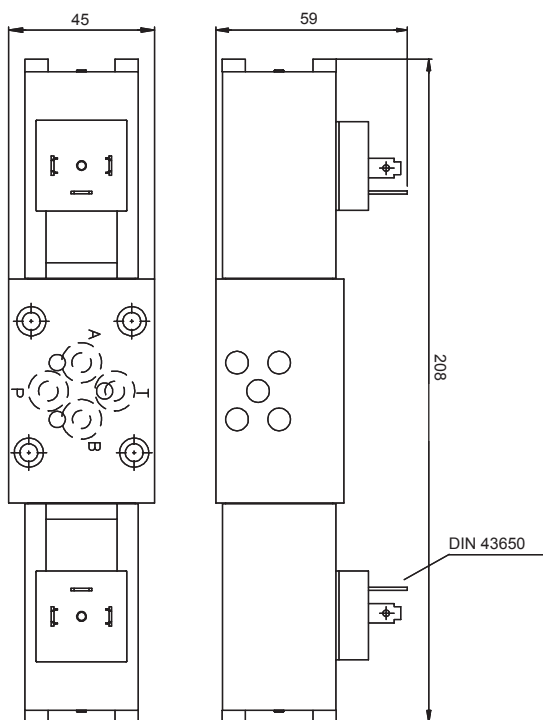
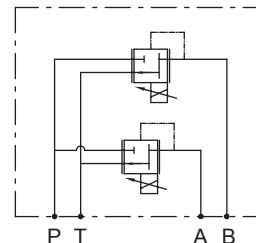

		VOLTAGE	
		1 (12Vcc)	2 (24Vcc)
REDUCED PRESSURE	1 (3÷18 bar)	3,7	15,5
	2 (3÷28 bar)	3,7	15,5
	3 (3÷33 bar)	4,8	19,3

Ordering code

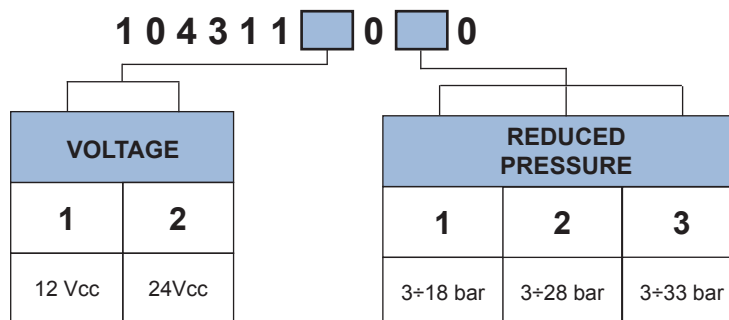

REMOTE CONTROL MANIFOLDS FOR HYDRAULIC

- Max working pressure in V **50 bar**
- Max working pressure in X:X1:Y:Y1 **28 bar**
- Max working pressure in L **1 bar**
- Max working flow **2 l/min**
- Leakage **16 cc/min**
- Seals **NBR**
- Max current at 12 Vcc **1800 mA**
- Max current at 24 Vcc **900 mA**
- Hysteresis **5%**
- PWM **120 HZ**
- Protection index with standard connector **IP-65**
- Weight **2,5 Kg**

SCHEME 0

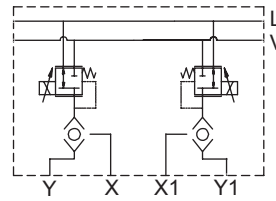

SCHEME 1

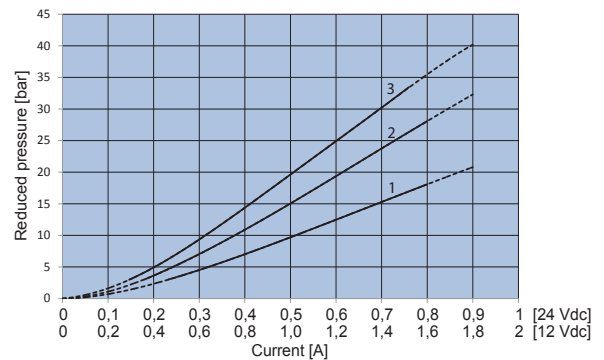
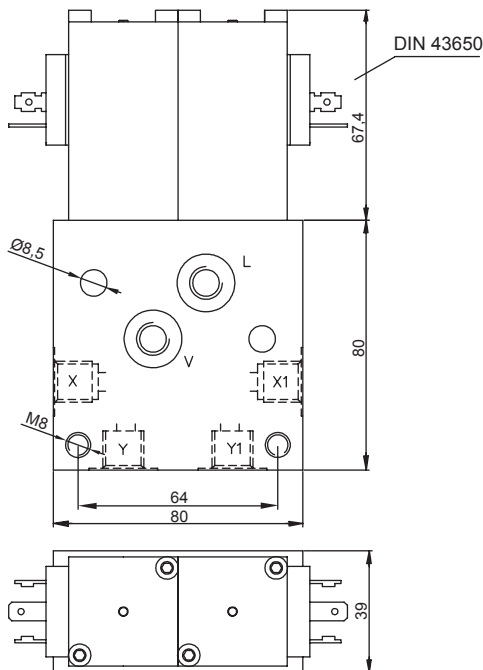
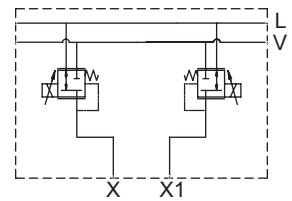

COIL RESISTANCE [Ω]		VOLTAGE	
		1 (12Vcc)	2 (24Vcc)
REDUCED PRESSURE	1 (3÷18 bar)	3,7	15,5
	2 (3÷28 bar)	3,7	15,5
	3 (3÷33 bar)	4,8	19,3

Ordering code

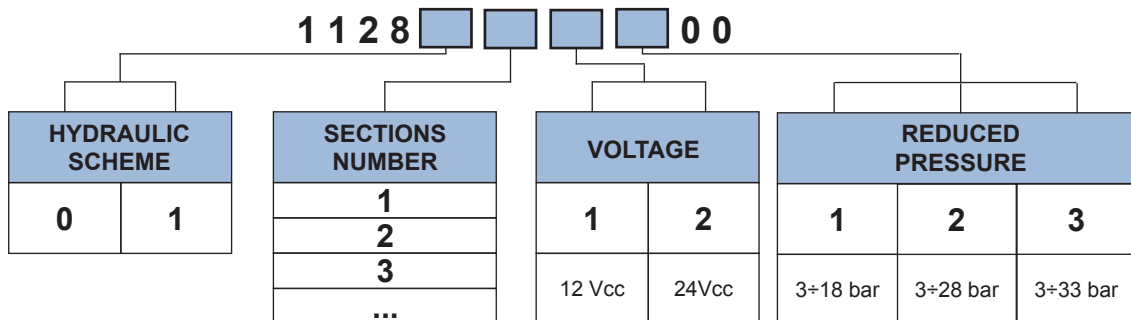

IN LINE SEQUENCE VALVE G3/8"

- Working flow. **60 l/min**
- Maximum working pressure. **350 bar**
- Check valve cracking pressure **< 0,5 bar**
- Weight. **0,186 Kg**
- Fixed setting

For customized settings contact the Nem customer care service

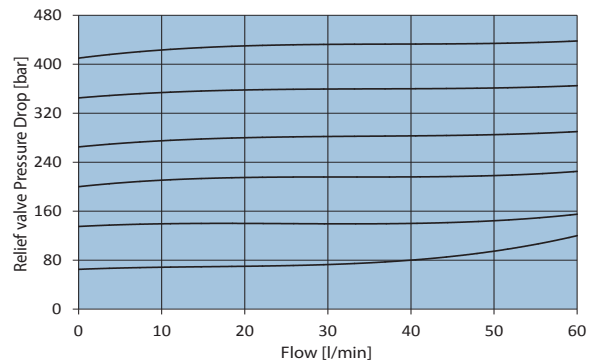
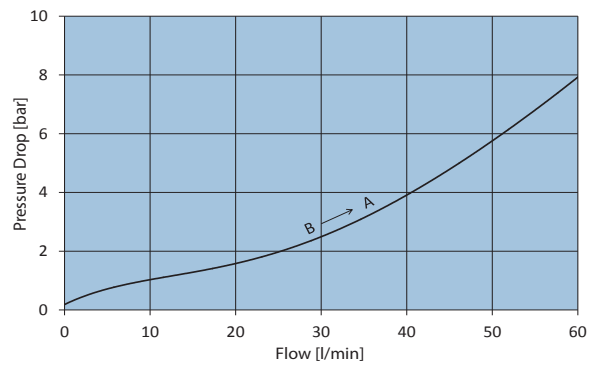
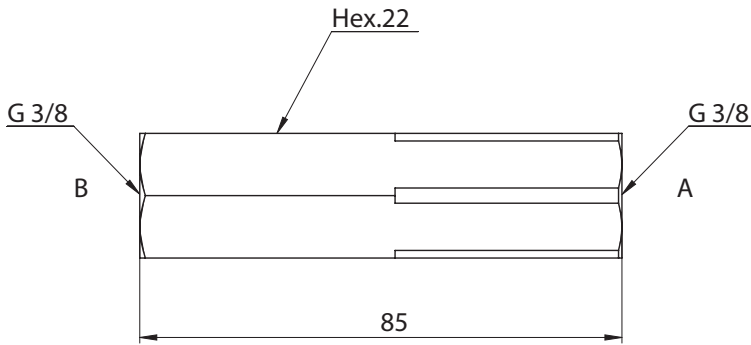
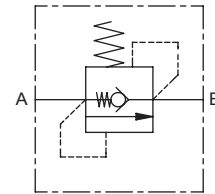

Ordering code

6 P 0 9 1 0 2 [] [] 0 0 0 0

SPRINGS	1	2	3	4	5
Setting range min - max [bar]	20 - 70	70 - 130	130 - 210	210 - 280	280 - 350
Standard setting [bar] @ 10 l/min	50	100	180	250	300

PORTS	03
A,B	G 3/8"



IN LINE SEQUENCE VALVE G1/2"

- Working flow **80 l/min**
- Maximum working pressure **350 bar**
- Weight **0,6 Kg**

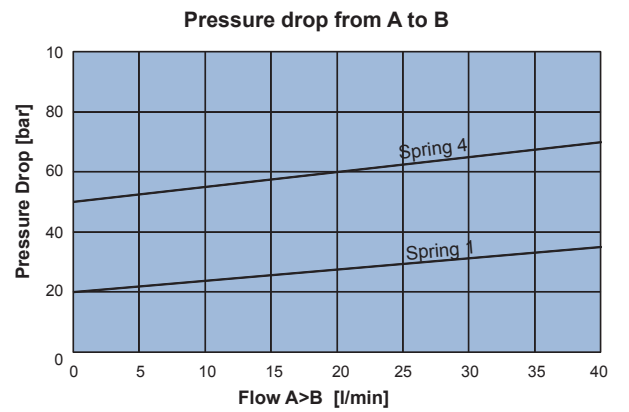
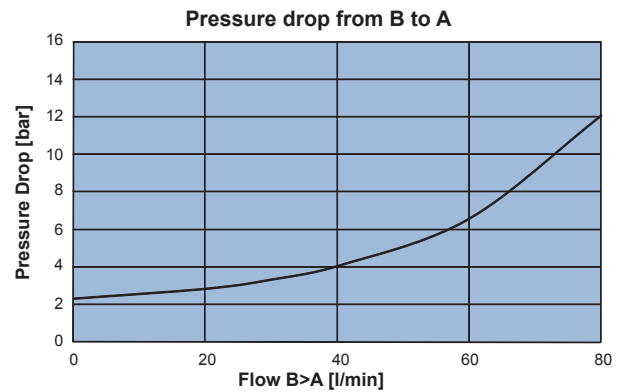
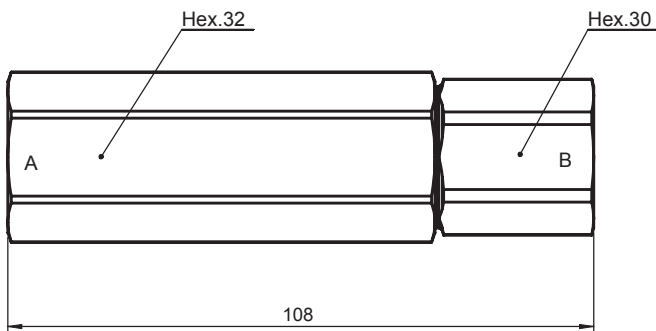
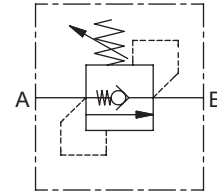

Ordering code

6 P 0 6 1 S 0 0 0 **0 0**

SPRINGS	1	4
Setting range min - max [bar]	10 - 30	25 - 90
bar/turn	9	28
Standard setting [bar] @ 4 l/min	20	50

PORTS	04
A,B	G 1/2"

DIRECT ACTING SEQUENCE VALVE G1/4", POPPET TYPE

- Flow.....**20 l/min**
- Maximum working pressure.....**210 bar**
- Check valve cracking pressure.....**2,5 bar**
- Weight.....**0,31 Kg**
- Tamper proof cap.....**cod. 9021015101**

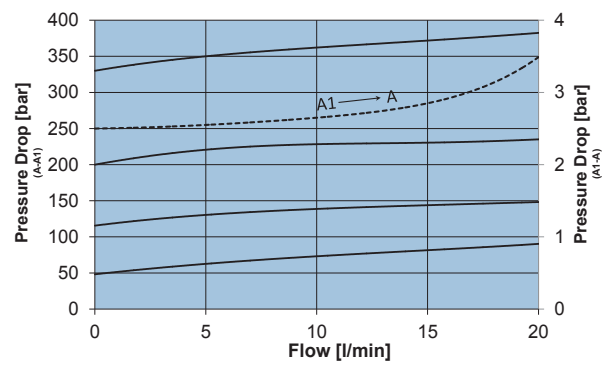
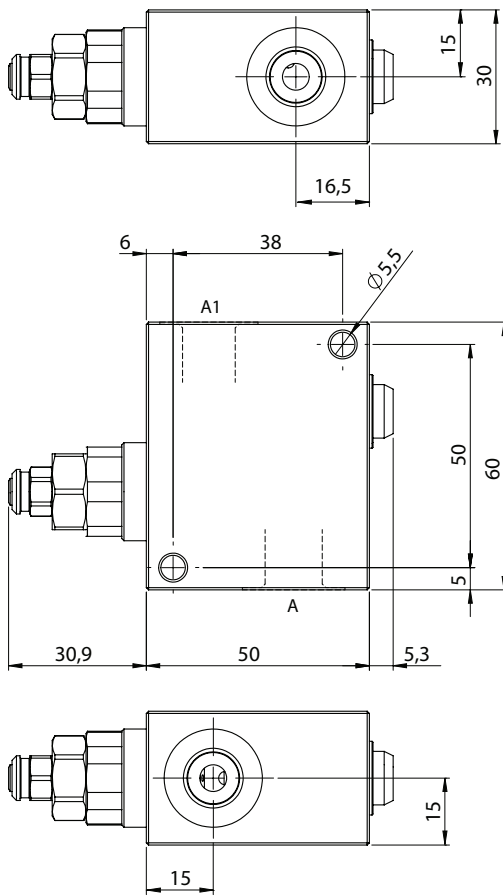
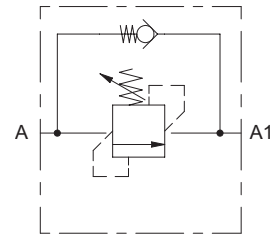

Ordering code

6 P 0 1 0 8 0 0 **A** **0 0**

SPRINGS	1	2	3
Setting range min.-max. [bar]	5 - 160	40 - 220	50 - 350
Pressure Increase [bar/turn]	36	34	63
Standard setting 4 l/min [bar]	50	100	250

PORTS	02
A,A1	G 1/4"



DIRECT ACTING SEQUENCE VALVE, POPPET TYPE

- Flow.....**30 l/min**
- Maximum working pressure.....**210 bar**
- Check valve cracking pressure.....**0,3 bar**
- Weight.....**0,64 Kg**

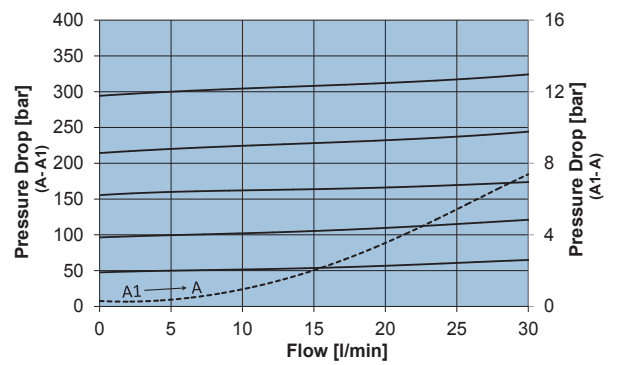
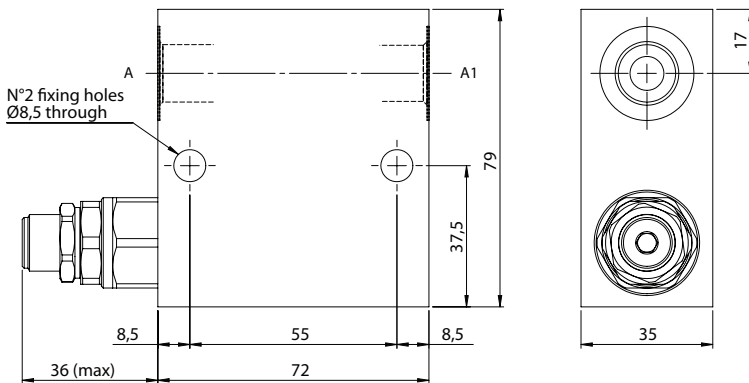
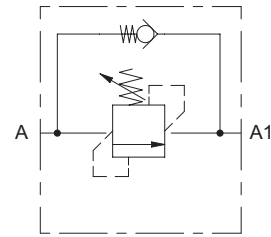

Ordering code

6 P 0 1 0 8 0 0 **A** **0 0**

SPRINGS	0	1	2	3
Setting range [bar]	15-50	50-120	120-200	200-350
Pressure Increase [bar/turn]	8	20	33	59
Standard setting 4 l/min [bar]	25	100	150	250

PORTS	03	04
A,A1	G 3/8"	G 1/2"

SEQUENCE VALVE, SPOOL TYPE - BACK PRESSURE COMPENSATED

- Flow **30 l/min**
- Maximum working pressure **210 bar**
- Check valve cracking pressure **0,3 bar**
- Weight **0,71 Kg**
- Tamper proof cap **cod. 9021030190**

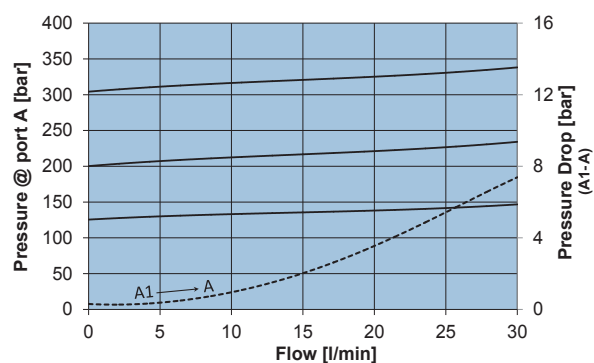
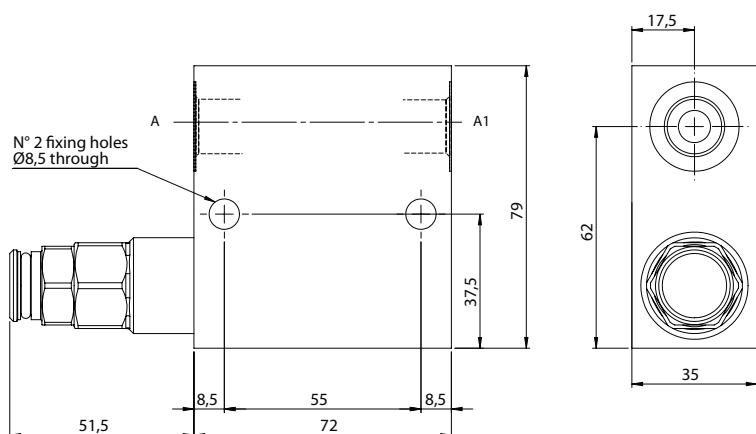
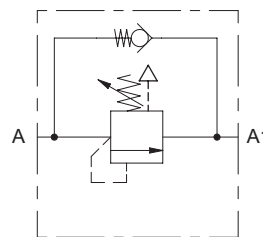

Ordering code

6 P 0 1 1 0 1 0 **A** **0 0**

SPRINGS	2	3
Setting range min.-max. [bar]	120 - 250	220 - 410
Pressure Increase [bar/by turn]	31	53
Standard setting 4 l/min [bar]	150	250

PORTS	03	04
A,A1	G 3/8"	G 1/2"



PILOT OPERATED SEQUENCE VALVE, SPOOL TYPE

- Flow **100 l/min**
- Maximum working pressure **210 bar**
- Check valve cracking pressure **0,5 bar**
- Weight **1,02 Kg**
- Tamper proof cap **cod. 4029250280**

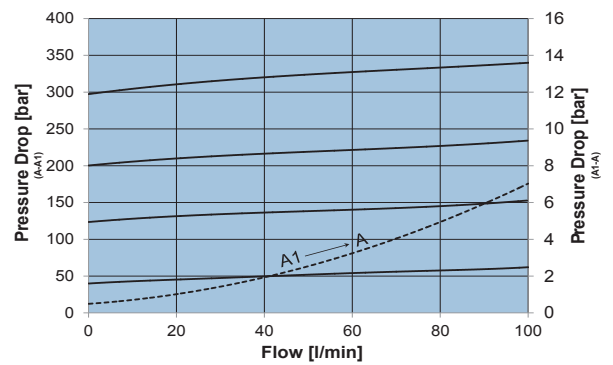
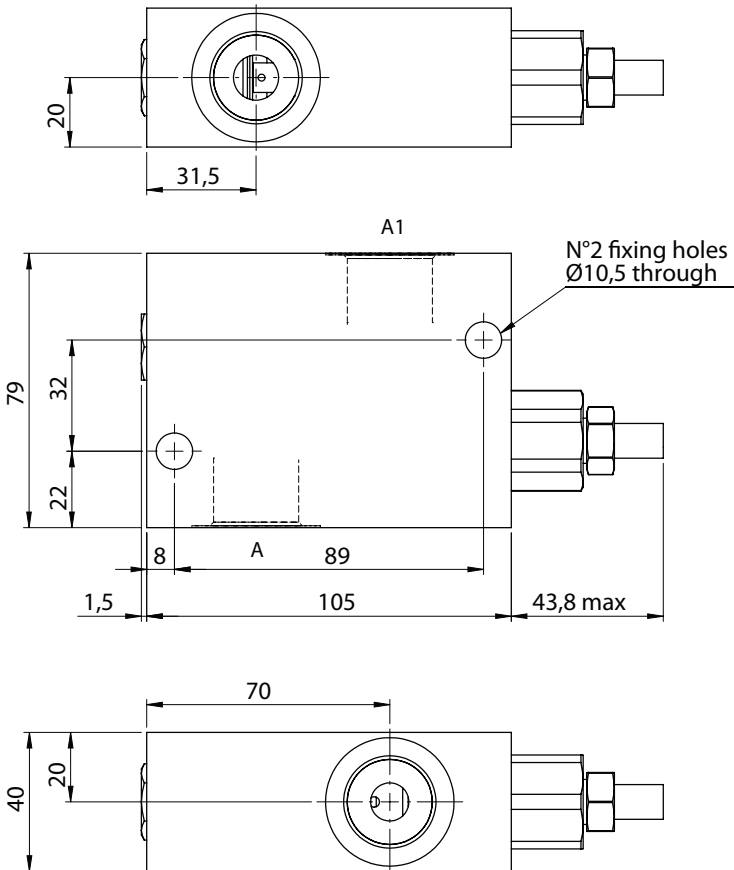
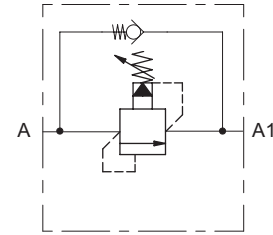

6 P 0 1 1 0 2 **A** **0 0**

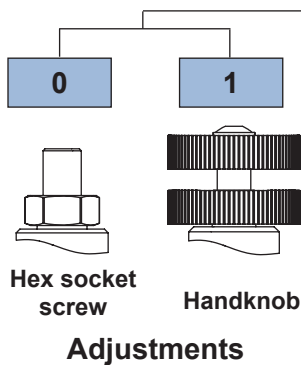

SPRINGS	3
Setting range min.-max. [bar]	20 - 350
Pressure Increase [bar/by turn]	136
Standard setting 4 l/min [bar]	100

PORTS	04	05
A,A1	G 1/2"	G 3/4"