

SINGLE ACTING PILOT OPERATED CHECK VALVE

- Flow **40 l/min**
- Max working pressure **210 bar**
- Weight **0,5 Kg**

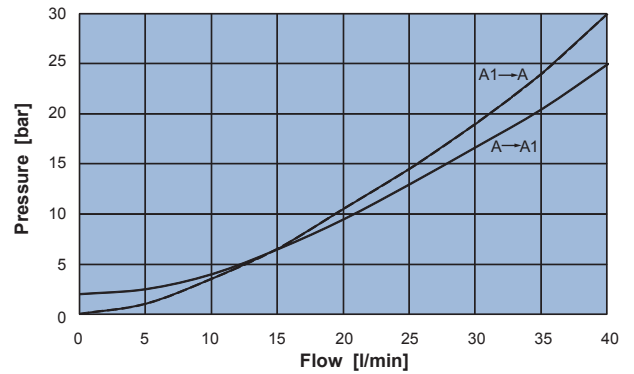
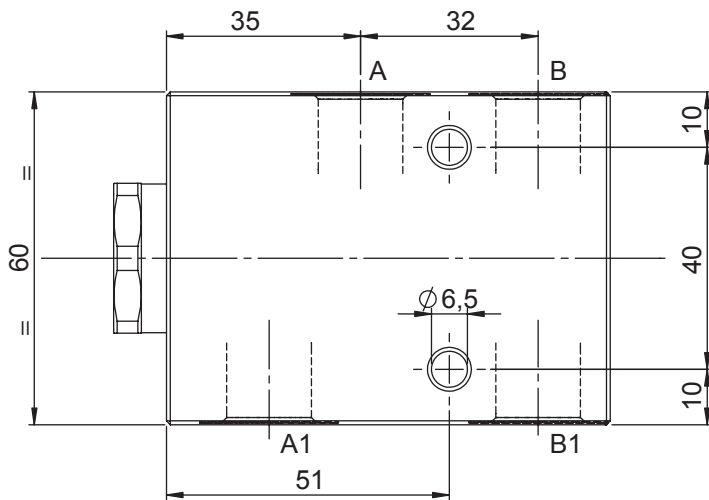
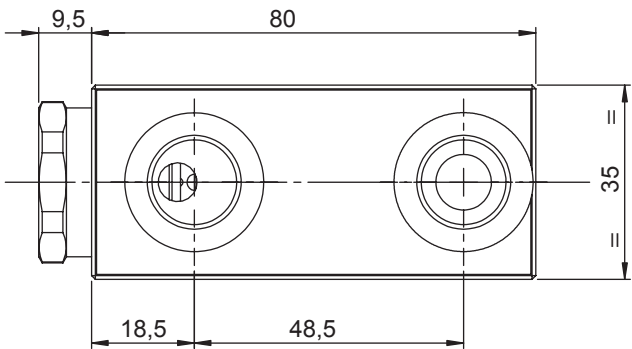
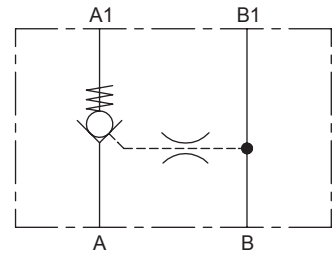

Ordering code

6 D 1 0 0 2 **A** **0 0**

PILOT RATIO	
70	7:1 without seal
7A	7:1 with seal

SPRING	1	2
Setting	2,0 bar	5,0 bar

PORTS	03
A,A1,B,B1	G 3/8"



SINGLE ACTING PILOT OPERATED CHECK VALVE

- Flow **60 l/min**
- Max working pressure **210 bar**
- Weight **0,5 Kg**

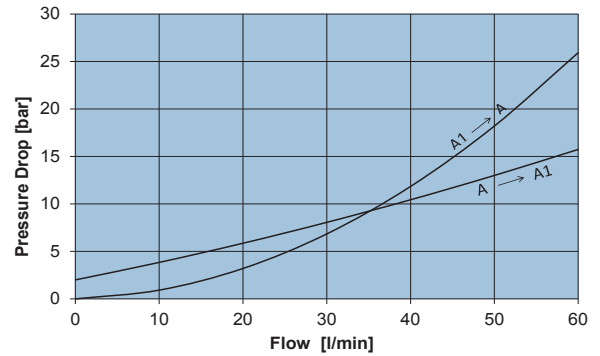
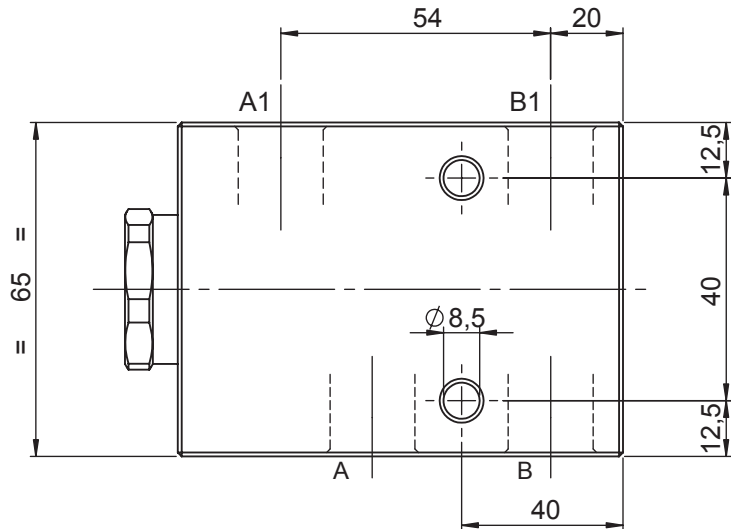
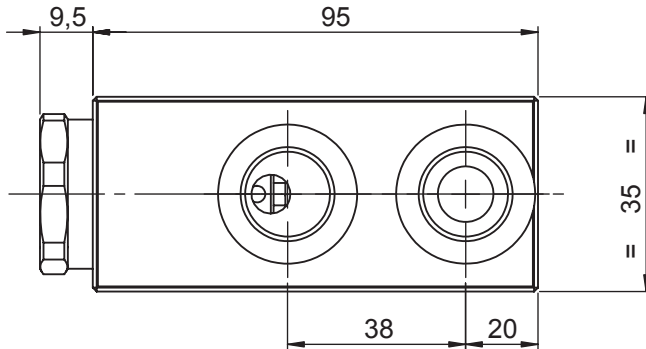
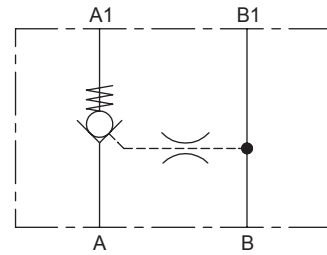

Ordering code

6 D 1 0 0 2 **A** **0 0**

PILOT RATIO	
50	5:1 without seal
5A	5:1 with seal

SPRING	1	2
Setting	1,5 bar	3,5 bar

PORTS	04
A,A1,B,B1	G 1/2"

SINGLE ACTING PILOT OPERATED CHECK VALVE - A1 PORT FLANGED

- Flow **40 l/min**
- Max working pressure **210 bar**
- Weight **0,5 Kg**

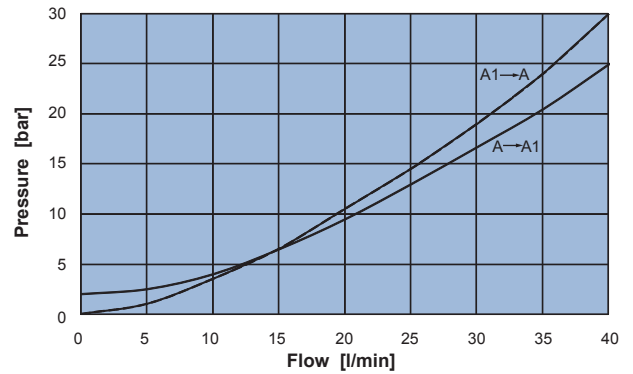
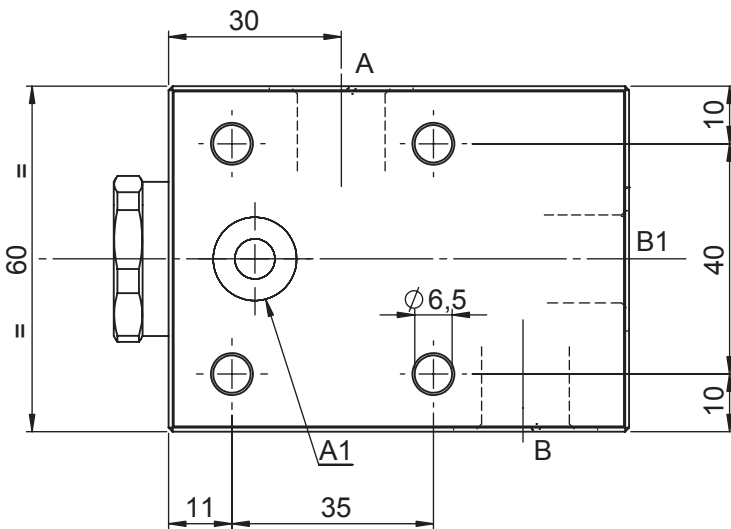
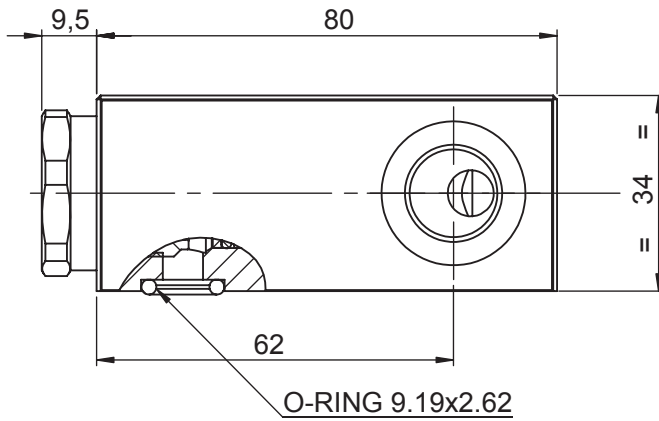
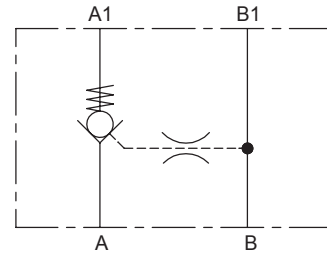

Ordering code

6 D 1 1 0 2 **A** **0 0**

PILOT RATIO	
70	7:1 without seal
7A	7:1 with seal

SPRING	1	2
Setting	2,0 bar	5,0 bar

PORTS	03
A,B,B1	G 3/8"
A1	Ø 7

