

SINGLE ACTING PILOT OPERATED CHECK VALVE WITH 2 POSITIONS MANUAL SHUT OFF - LEFT

- Flow **30 l/min**
- Max working pressure **210 bar (Aluminium Body)**
- Weight **0,5 Kg**
- Lever **Lever/Handknob**

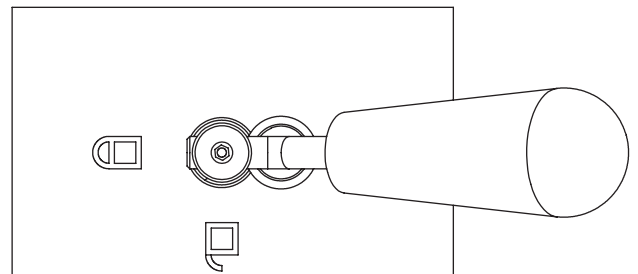
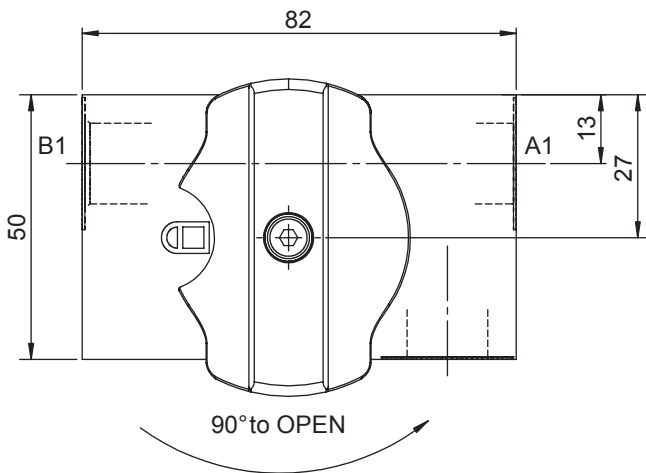
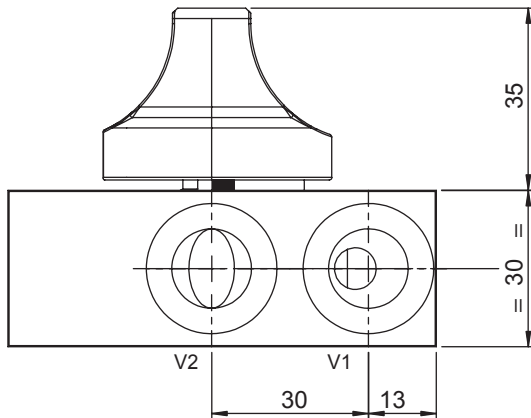
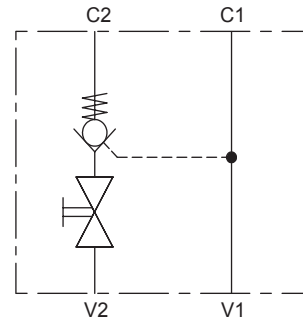

Ordering code

6 D [] 0 0 B [] [] A [] 0 0

LEVER		PILOT RATIO		SPRING	1	PORTS	03
3	5	5A	4,7:1 with seal	Setting	2,7 bar	A,A1,B,B1	G 3/8"

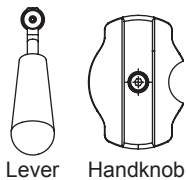

SINGLE ACTING PILOT OPERATED CHECK VALVE WITH 2 POSITIONS MANUAL SHUT OFF - RIGHT

- Flow **30 l/min**
- Max working pressure **210 bar (Aluminium Body)**
- Weight **0,5 Kg**
- Lever **Lever/Handknob**

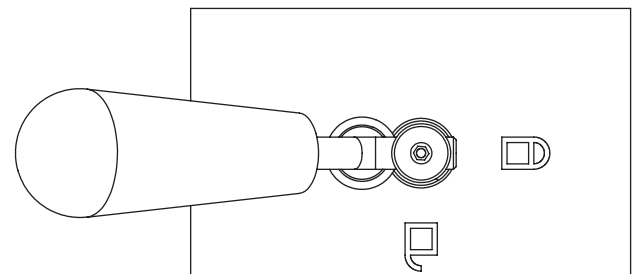
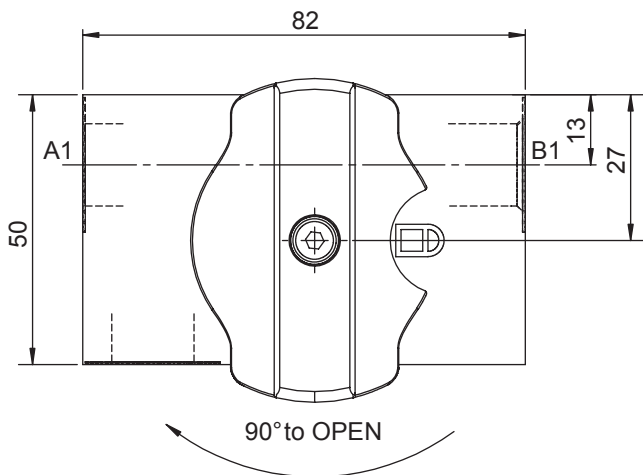
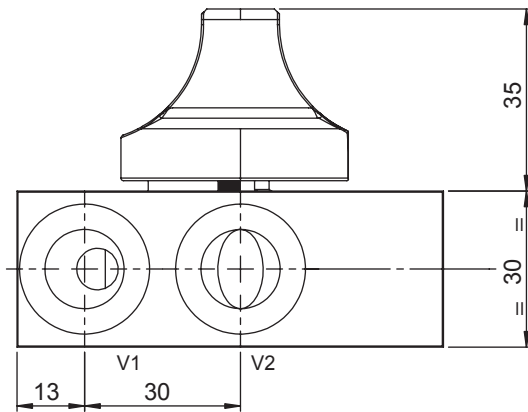
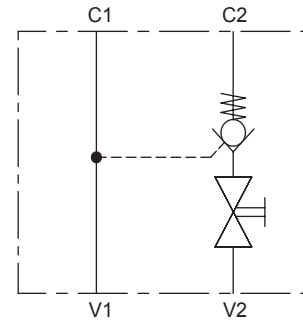

Ordering code

6 D [] 1 0 B [] [] A [] 0 0

LEVER	
3	5

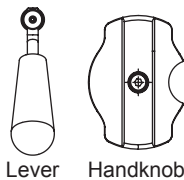

PILOT RATIO	
5A	4,7:1 with seal

SPRING	
1	Setting 2,7 bar

PORTS	
03	A,A1,B,B1 G 3/8"